



LP 92 \_ LP 101 \_ LP 105 \_ LP 201 \_ LP 301



COLGEM



## Gold Panwasher is your most faithful partner

To wash and sanitize in a quick, efficient, economic way and fully corresponding to the hygienic-sanitary norms. This is the request of all the costumers who in their every-day activity are using baking trays, pans, utensils, baskets in contact with foods. Colged gives an answer to this question with the Gold panwasher.

Five models of growing capacities make it possible for every kind of user to find his ideal machine. Special baskets and accessories allow the washing of every kind of wares, sophisticated constructive technologies, as the **Total Clean Concept**, are used to make the panwasher's use easier and less tiring.

The exclusive CRP rinse System ensures a perfect kitchen ware's hygiene, while the washing arms with their special star shape contribute to obtain an impeccable cleanliness. Solid and reliable the Gold panwashers will be a golden partner for your business!

**SINCERT**



# Gold, the ideal support for your business



## Pastry shop, bakery

The Colged panwashers are ideal for both the washing of the 60 and 85 cm baking trays, but also for baskets, containers of every measure, "planetary" tanks, utensils and funnels. The possibility to regulate the washing and rinsing temperatures makes it possible to treat in a great way different types of substances, from the egg to the chocolate.



## Ice-cream shop, food processing

Laboratories of every type and dimension, butcher's shops, fish-markets, can find inside the Colged range the most suitable instrument for the washing of baking trays, Gastronorm basins, knives, utensils, mixers or "planetary" tanks. The three selectable washing cycles permit you to adapt the productivity to any particular kind of dirt while the door and the stainless steel basket's ergonomic construction reduce the operators' fatigue.

*With Gold 92 you can wash plates  
and glasses as well*



## Restoration, gastronomy

Pots, baking trays, utensils, Gastronorm containers, all of which you can find in a kitchen can be washed in the Colged panwashers. The continuous washing cycle allows you to treat even the obstinate dirt while the "Total Clean Concept" philosophy makes fast and light the cleaning operations at the end of the day.



## With Gold you can



1

### Saving time and money

Time can't be bought. The Gold panwashers give it to you as a gift. LP 101 can, for instance, wash up to 150 baking trays in an hour, that means less time passed in tedious cleaning operations at the end of the day. Furthermore, the completely automatic functioning makes the operators able to dedicate themselves to other activities during the washing in order to have an optimal exploitation of time. The Gold project was born to consume reduced quantities of water, energy and detergent, thanks to the shrewdness like the CRP rinse system that exploits at its best the thermal energy generated in the boiler or the particular double-walled construction that reduces the thermal loss of heat. So, always considering LP 101, the washing of a baking tray can cost even only **1 Euro cent** (hot water fed machine).



2

### Helping the personnel

The Gold panwashers are thought to make faster and easier the tedious **cleaning operations at the end of the day** thanks to the **Total Clean Concept** while the design inspired to the most advanced ergonomic principles reduces the fatigue. The functioning then is intuitive and the machine control is made through a soft touch low tension electric panel with few push buttons of immediate understanding, clear pilot lights and big digital displays for the visualisation of the washing and rinsing temperatures. The same displays also visualise the self diagnostic system's messages which control the main electric components, highlighting possible malfunctions: in this way also the maintenance's operations and their cost are sensibly reduced.

1. Thanks to the rounded corners and the lack of pipes the wash chamber is extremely easy to clean
2. Low voltage soft touch control panels
3. Double skinned interlocked doors. Quiet and highly ergonomic



3

### Ensuring the hygiene

The objects' sanitation is made thanks to the water's high temperature action and the CRP system has unattainable performances in this field. The guarantee of a rinse always at a sanitation temperature is given by the sophisticated **electronic Thermostat** that doesn't permit the start of this crucial phase if the water isn't at the correct temperature. Gold pays attention also to the work's environment, in fact the double-walled construction and the particular washing circuit's architecture have permitted to reach an extraordinary **silence**. The reduction of the consumption of water and chemical products sensibly decreases the impact of every single cycle on the environment. The Gold panwashers allow you to comply with **HACCP** normative requirements in an easy and economical way.



# Refined technology

## CRP

CRP is the system developed by Colged for those costumers who are looking for perfection. The CRP rinse in fact permits you to enjoy the quality's constancy , as the rinse water's temperature doesn't change for the whole cycle duration, and the constancy's quality as the water's capacity and pressure are always fixed on optimal values independently from the surroundings conditions. All this thanks to the circuit's refined architecture that foresees an atmospheric boiler not directly fed from the water line but from an intermediate tank, according to the WRC antipollution standards, and a rinsing pump in aspiration, everything located inside the machine's body.

### Traditional rinse



### Traditional rinse

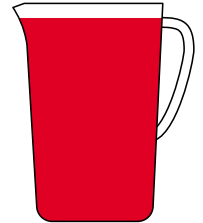
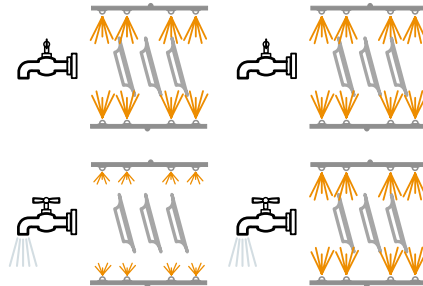

## Total Clean Concept

It' s the Colged projecting philosophy which makes us adopt every possible shrewdness to make the machine's maintenance easier in perfect hygienic conditions. As prevention is better than cure, the Gold panwashers are equipped with moulded tanks with "out of water" welding and washing chambers without internal pipelines , in order not to offer any points of accumulation to the dirt . The double integral filters retain the biggest particles, conveyed to proper collection baskets easily extractable. Finally , the pumps are self draining in order to avoid the bad smells' coming out when the machine is shut off.



4

- 4. Deep drawn tank, the dirty has no shelter!
- 5. Highly effective star like wash arms



5



## Colged Gold LP range



### LP 92

Economic and compact it is ideal for little laboratories and for all the situations where it is necessary to dispose not only of a little panwasher with great features, able to wash also 60 x 40 cm backing pans, but also a versatile dishwasher. Lp 92 can take without modifications all the baskets of Colged's program and with the special "maxi" basket (optional) it can wash up to 720 standard dishes or 360 pizza dishes with 40 cm maximum diameter in an hour.



### LP 101

Its wide "55 x 61 cm" basket and the 65 cm clearance make it able to operate in the most different activity sectors. The doubled guillotine and swing door reduces sensitively the effort required by the operator. LP 101 is the most widespread in laboratories and supermarkets.



### LP 105

A favourite among the pastry shop and bakery sector it can treat also 85 cm backing trays and it is equipped with a powered washing pump to assure great washing performances even with "out of standard" heights.



### LP 201

With a 70 x 70 capable basket and a 65 cm clearance, LP 201 is the most diffused general use machine in food processing, gastronomy and in general collective restoration. The powerful washing pump with an elevate water capacity ensures a great washing effectiveness.



### LP 301

The 132 x 70 cm basket and the clearance make it able to answer to the big users' expectations in the most different sectors; the wide washing chamber is perfectly covered thanks to the action of two powerful pumps, each of which acts on two star arms with three radius each. The basket, as in all Gold's panwashers, slides on solid clutch sliders that are reducing the effort required for the movement even when fully loaded.

Table of technical data		LP 92	LP 101	LP 105	LP 201	LP 301
Crp Rinse		yes	yes	yes	yes	yes
Rack dimensions	cm	50 x 60	55 x 61	55 x 61	70 x 70	132 x 70
Wash cycles	sec	120/240/360	120/240/360	120/240/360	120/240/360	120/240/360
Continuous wash		yes	yes	yes	yes	yes
Wash pump	Lt/min	600	650	900	1200	2 x 1200
Max Power	Kw	7,1	7,4	8,0	11,0	15,5
Voltage	V/ph/Hz	230-400/3/50	230-400/3/50	230-400/3/50	230-400/3/50	230-400/3/50
Water consumption	Lt/cycle	3,5	4	4	5	8
Water feed	°C	15 - 55	15 - 55	15 - 55	15 - 55	15 - 55
Water feed	bar	1-4	1-4	1-4	1-4	1-4



### LP 92

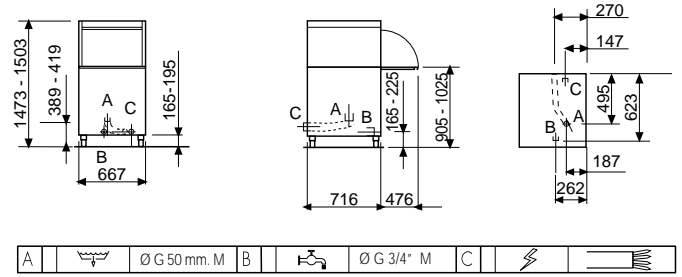

A		Ø G 50 mm. M	B		Ø G 3/4" M	C		
---	--	--------------	---	--	------------	---	--	--

### LP 101

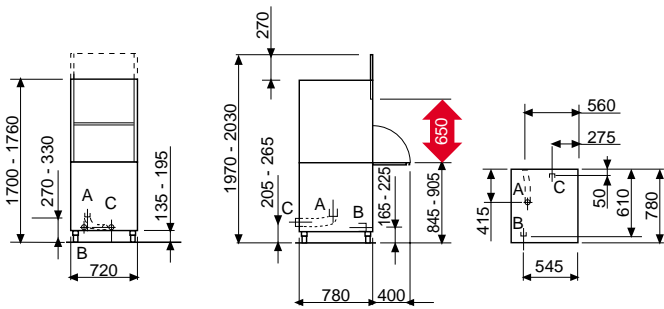

A		Ø G 50 mm. M	B		Ø G 3/4" M	C		
---	--	--------------	---	--	------------	---	--	--

### LP 105

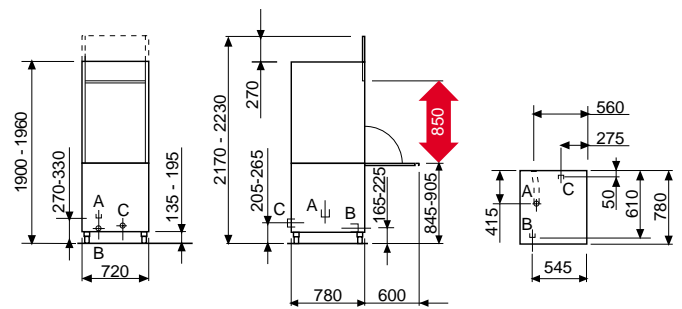

A		Ø G 50 mm. M	B		Ø G 3/4" M	C		
---	--	--------------	---	--	------------	---	--	--

### LP 201

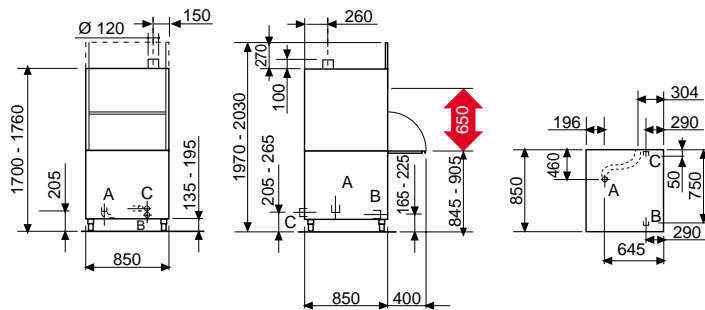

A		Ø G 1" 1/2 M	B		Ø G 3/4" M	C		
---	--	--------------	---	--	------------	---	--	--

### LP 301

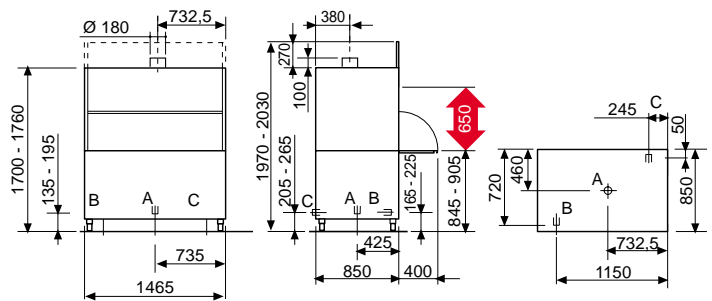

A		Ø G 2" M	B		Ø G 3/4" M	C		
---	--	----------	---	--	------------	---	--	--

design: Alessandro Rinaldi - foto: Marcato Tibbiani

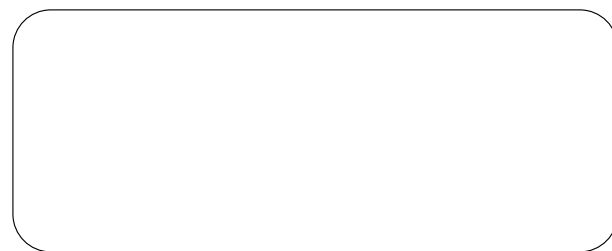

MD-LP - 10/2005 - UK