

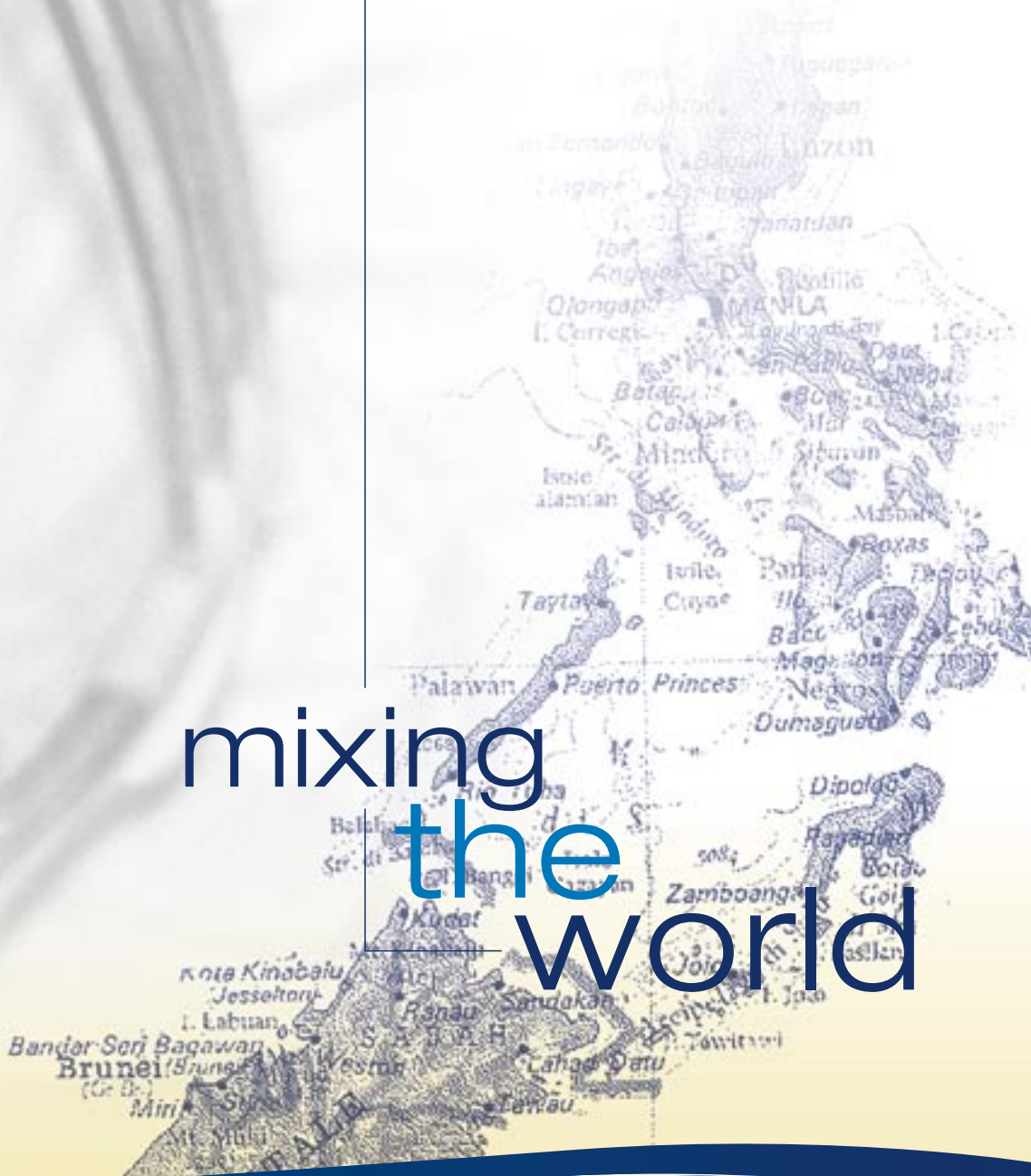

STARmix
bakery and pastry equipment

INDUSTRIAL
industrial

mixing
the
world



Caratteristiche tecniche

Technical features · Caracteristiques techniques
 Caracteristicas tecnicas · Technische merkmale

- 
 - ▶ Accessori di serie: vasca, frusta a fili sottili, spatola e spirale
 - ▶ Accessori optional: frusta a fili grossi, gancio, carrello e raschiatore
 - ▶ Gli accessori sono completamente in acciaio inox
 - ▶ Struttura in acciaio verniciato
 - ▶ Saliscendi della vasca automatico
 - ▶ Protezioni antinfortunistiche secondo la normativa CE

- 
 - ▶ Standard accessories: bowl, fine wire whisk, paddle and spiral
 - ▶ Optional accessories: heavy wire whisk, hook, trolley and scraper
 - ▶ Bowls and tools in stainless steel
 - ▶ Enamelled steel structure
 - ▶ Automatic bowl lifting/lowering system
 - ▶ Safety cover devices respecting CE regulation

- 
 - ▶ Accessoires de serie: cuve, fouet avec les fils fins, palet et spiral
 - ▶ Accessoires optional: fouet avec les fils gros, crochet, chariot et racloir
 - ▶ Cuve et outils en acier inox
 - ▶ Construite en acier verni
 - ▶ Relevage automatique de la cuve
 - ▶ Protections contre les accidents conforme aux normes CE

- 
 - ▶ Accesorios de serie: cubeta, batidor, espatula y espiral
 - ▶ Accesorios optional: batidor, gancho, carro y rasqueta
 - ▶ Cubeta y utensillos en acero inoxidable
 - ▶ Estructura en acero barnizado
 - ▶ Levantar de la cubeta automatico
 - ▶ Protecciones contra los infortunios CE

- 
 - ▶ Serienzubehöre: schüssel, peitsche mit dünnen fäden, spatel und spirale
 - ▶ Zubehöre in option: peitsche mit dicken fäden, haken, wagen und abkratzer
 - ▶ Die zubehöre sind ganz aus edelstahl
 - ▶ Struktur aus gestrichnem stahl
 - ▶ Automatische auf- und abwärtsbewegung des schüssels
 - ▶ Umfallschutzvorrichtungen gemäss CE-norm



mescolatrici planetarie

planetary mixers

mélangeuses planétaires

mezcladoras planetarias

planeten - mischgeräte

PL80T



PL80T - PL80TS

3 velocità

3 speeds

3 vitesses

3 velocidad

3 geschwindigkeiten



Variatore elettronico

Electronic variator

Variateur electronique

Variador electronico

Elektronischer wandler



INDUSTRIAL

industrial

L80TS



Vasca
Bowl - Cuve
Cubeta - Schüssel



Frusta a fili sottili
Fine wire whisk - Fouet
Batidor - Ruhrbesen



Frusta a fili maggiorati
Heavy wire whisk - Fouet
Batidor - Ruhrbesen
optional



Spatola
Beater - Palet
Espatula - Schaber



Spirale
Spiral - Spirale
Espiral - Spiralgerat



Raschiatore
Scraper - Raclor
Rasqueta - Abkratzer
optional

PL120T - PL140T



PL120T · PL140T



Variatore elettronico
Electronic variator
Variateur électronique
Variador electrónico
Elektronischer wandler



Variatore elettronico+PLC
Electronic variator+PLC
Variateur électronique+PLC
Variador electrónico+PLC
Elektronischer wandler+PLC

CODICE MACCHINA* MACHINE CODE* CODE MACHINE* CODIGO MAQUINA* MASCHINENKODE*	VASCA BOWL CUVE CUBETA SCHÜSSEL Lt.	DIMENSIONI DAIMENSION DIMENSIONES DIMENSIONES ABMESSUNGEN mm (AxBxC)	PESO WEIGHT POIDS PESO GEWICHT Kg	POTENZA POWER PUISSANCE POTENCIA MOTORSTARKE Kw
PL80T3VA	80	1100x745x1480h	375	1,2/2,5/3,1+0,75
PL80TVAREA	80	1100x745x1480h	375	4,0+0,75
PL80T3VAS*	80	1100x745x1715h	410	1,2/2,5/3,1+0,75
PL80TVAREAS*	80	1100x745x1715h	410	4,0+0,75
PL120TVAREA	120	1260x920x1980	520	5,5+0,75
PL120TVAREAP **	120	1260x920x1980	520	5,5+0,75
PL140TVAREA	140	1260x920x1980	540	5,5+0,75
PL140TVAREAP **	140	1260x920x1980	540	5,5+0,75

* Versione speciale (s): estrazione della vasca senza rimozione dell'utensile mescolatore
 * Special version (s): unlocking the bowl without removing the mixing tool
 * Version special (s): décrochement de la cuve sans déplacer l'outil
 * Version especial (s): extracción de la cubeta sin remover el utensillio mezclador
 * Sonder version (s): die entdperung des schüssels erfolgt ohne entfernung des mischapparats

** Versione con PLC: la macchina può lavorare con ciclo automatico o manuale
 ** PLC version: the machine works by automatic or by manual operating cycle
 ** Version PLC: la machine fonctionne par un cycle automatique ou manuel
 ** Version PLC: la maquina puede funcionar en ciclo automatico o manual

PL120T - PL 140T

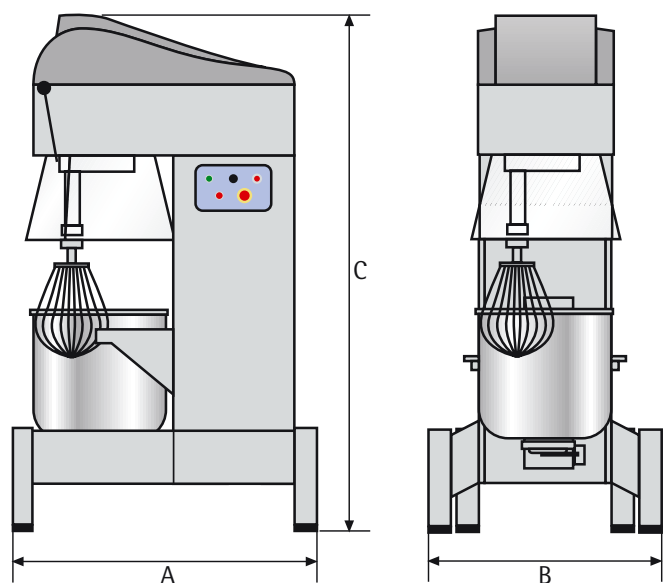

PL80T - PL80TS

