



sottoriva

Your future, our technology.



DINAMICA

DINAMICA

Is our OIL FREE, heavy duty dough divider / rounder at 4-5 or 6 rows. Ideally suited for dividing and rounding a variety of doughs which undergo further processing to obtain a round, moulded, flattened, or long rolled shapes that we identify as hamburger and hotdog buns, finger rolls, sub rolls or hoagies, bolillos, petit pains, brioche, pita bread, pizza bread, egg buns and dinner rolls. The DINAMICA is suitable for working soft and semi-hard dough, and, it is standard with a Teflon coated stainless steel hopper with an approximate of 25kg (55 lbs.) of dough capacity.

All dough types are handled gently, thanks in part to the combination of our star wheel dosing system, and, an adjustable spring system for the pressure in the portioning chambers. These simple operator control features substantially reduce any stress to dough that is coming from the mechanical action of the machine. The added benefit is realized as the DINAMICA has a very accurate dough weight control, due to the reduced stress in the dough cell structure

After the weight of the dough ball is determined, the pieces of dough are discharged from the pistons and deposited into our innovative rounding drum design with the double weight range.

Compared to regular rounding systems, this new and innovative design of our rounding system accommodates a very large range of varied dough weight on one drum.

Upon completion of the rounding cycle, the dough balls are transferred onto the discharge conveyor belt for pick-up (by hand), or to be further conveyed to attached moulding equipment (for product shaping and forming).

Production is electronically variable from 800 to 1600 pcs/hour per row.

The DINAMICA is available with touch-screen control panel, with 50 storable programs, that controls and stores all the machine functions, from adjustment of sizes to rounding and production speed.



The panel also has a diagnostics screen to identify possible operational problems. Further, the panel can identify conflicts where the dough weight, the production speed, and, the overall machine speed are non-synchronous, mechanically or through the potentiometer.

The "NEW" DINAMICA "E" electronic version control panel is also supplied with a USB key port and an Ethernet RS232 cable connection in order to upload or download program modifications into the PLC (if required), store the machine programs(externally), or, to update the software to or from a PC connection for a change to the machine control.



Due to the innovative design of the rounding drum, the DINAMICA, with only one drum, can cover the entire weight range in one single machine execution, and, of course, with the highest standard for rounding that only a drum system can deliver at the maximum speed of hourly production.

Our INNOVATIVE special double size rounding drum which allows a very wide range of dough weights. This is a real innovative design for the most UNIQUE dough divider and rounder machine named DINAMICA for the bakery that needs a wide range of flexibility for their customer's product requirements.



DINAMICA is produced in 3 different models, the DINAMICA 4, 5, or 6 pockets. Each model has different versions and the customer can choose one, two, or all the variables inside the same model. Different versions (factory set) can be modified later to meet the changing needs of the client, with the purchase and installation of a special kit of "changeover" pistons and the rounding drum.

	Choice of dividing set up		Weight Range	Hourly Capacity
DINAMICA 4	1	X	20-50 gr (0.70-1.76 oz)	6400 PCS
	2	X	30-90 gr (1.05-3.17 oz)	6400 PCS
	3	X	80-130 gr (2.82-4.58 oz)	6400 PCS
	4	X	120-180 gr (4.23-6.35 oz)	6400 PCS
DINAMICA 5	1	X	20-50 gr (0.70-1.76 oz)	8000 PCS
	2	X	40-110 gr (1.41-3.85 oz)	8000 PCS
	3	X	80-130 gr (2.82-4.58 oz)	8000 PCS
DINAMICA 6	1	X	20-50 gr (0.70-1.76 oz)	9600 PCS
	2	X	40-110 gr (1.41-3.85 oz)	9600 PCS



The special plastic material allow the machine to be OIL FREE. This feature provides a huge advantage to the baker, by reducing the time required for maintaining a clean machine, being a great money saver to rid the need for divider oil for machine operation. NO OIL, NO MESS, SAVES MONEY!

Cleaning the machine after every production run is very easy and just takes a few minutes. Faster clean-up yields more operation time and profits, so it pays for the customer to take care of his DINAMICA machine so it will last for ever.



Solid and heavy duty out feed belt for hand panning (Standard).



Finger belt to connect the Dinamica with a moulding station or a line (Optional).

DINAMICA can work with different types of dough: HARD, MEDIUM, and “SOFT and STICKY”, thanks to different set-ups available.

These great features make the DINAMICA very flexible and user-friendly, while delivering the Baker the possibility to use ONE machine for his/her production.

DINAMICA Overall Dimensions

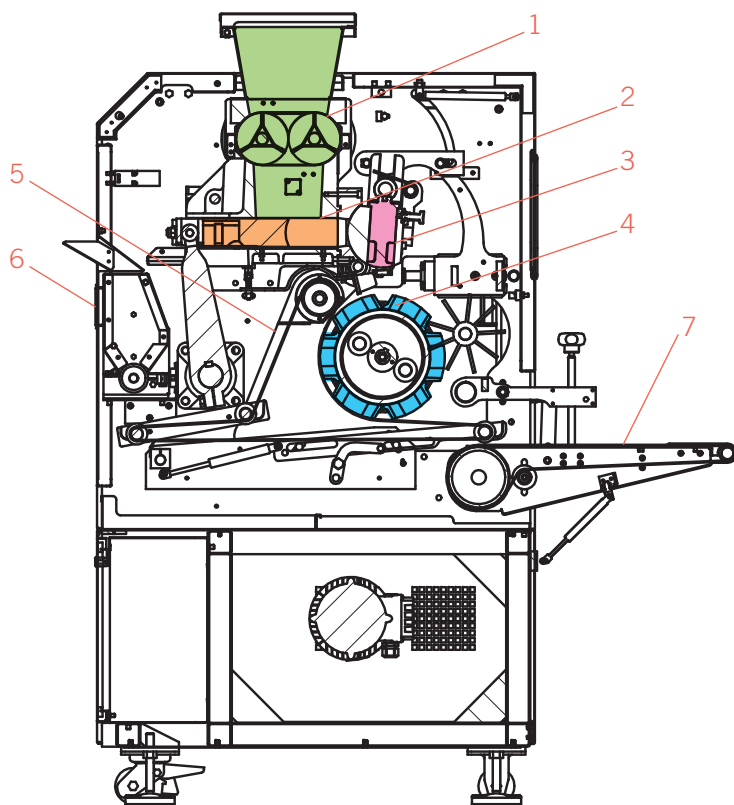

LEGEND

- 1) Stress Free Dividing Star System;
- 2) Dividing Chamber;
- 3) Dividing Pistons;
- 4) Rounding Drum;
- 5) Rounding Belt;
- 6) Flour Duster;
- 7) Exit Belt;

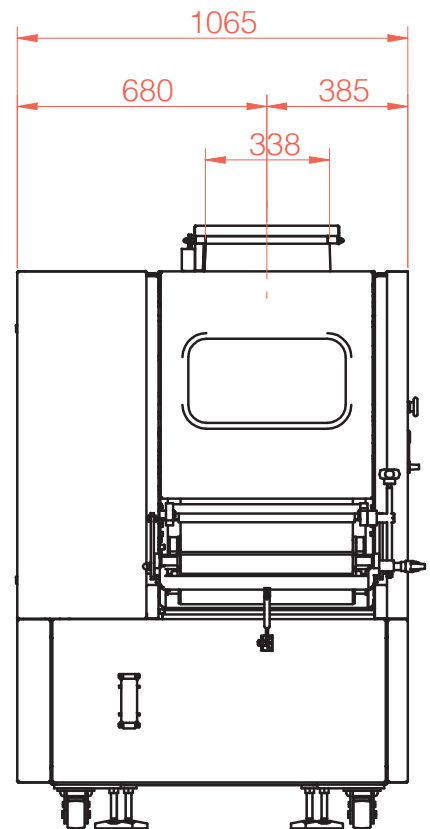
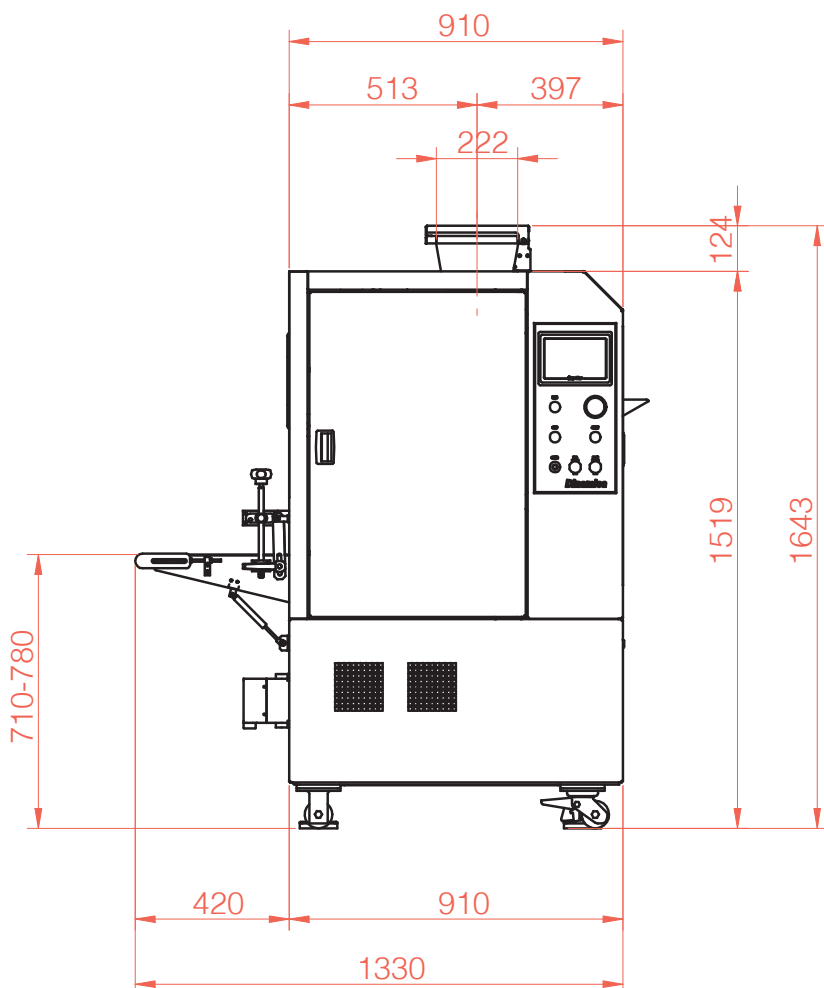



SOTTORIVA S.p.A.

Via Vittorio Veneto, 63
36035 Marano Vicentino (VI) ITALIA

Tel. +39.0445.595111
Fax +39.0445.595155

sottoriva@sottoriva.com
www.sottoriva.com



SOTTORIVA AMERICA INC

620- C Griffith Road
Charlotte, NC 28217 - USA

Tel: +1(704).841.9546
Fax +1(704).714.5881

sottorivaamerica@sottoriva.com
www.sottoriva.com